

Temperature Probes for Industrial Applications

HI 7610, HI 7611, HI 7620 and HI 7621

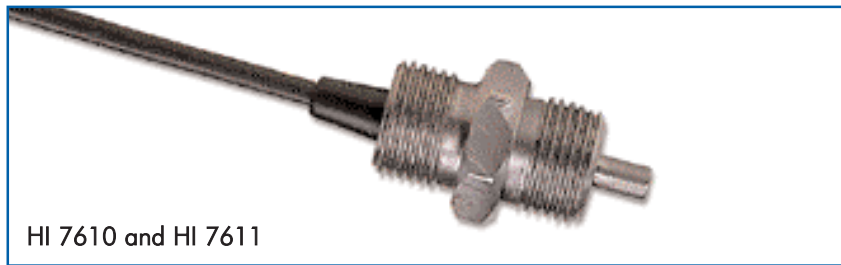
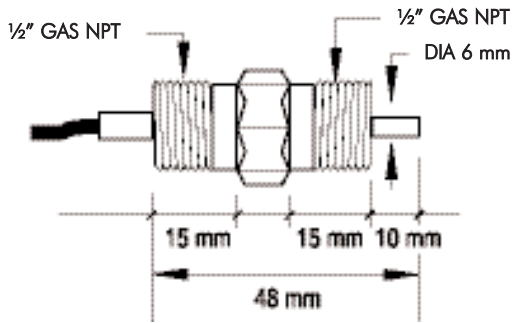

HI 7610 and HI 7611

Specifications

	HI 7610	HI 7611	HI 7620	HI 7621
Temperature Sensor	Pt100	Pt1000	Pt100	Pt1000
Body	stainless steel	stainless steel	glass	glass
Max Pressure	8 bar	8 bar	3 bar	3 bar
Cable Length	5 m (16.4')	5 m (16.4')	5 m (16.4')	5 m (16.4')

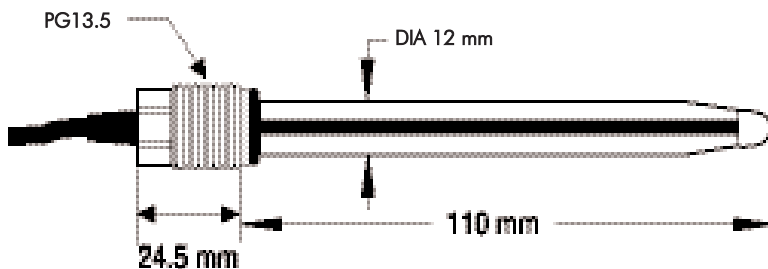

- Flow-thru and immersion mounting
- High accuracy
- Stainless steel model with 1/2" GAS NPT external thread
- Glass version with high chemical resistance and PG 13.5 external thread

HANNA instruments® presents temperature probes with 3-wire Pt100 or Pt1000 sensor. These probes provide an accurate and effective way of measuring and compensating for temperature. They can be used with a vast array of industrial pH, ORP and conductivity controllers on the market, as well as our pH 500, mV 600, HI 700 & HI 504 series.

HI 7610 and HI 7611 are constructed of stainless steel for additional ruggedness. They incorporate 1/2" external threads on both ends to facilitate in-line and immersion installations.

HI 7620 and HI 7621 are made with a glass body in order to provide greater resistance against aggressive chemicals. They also come with a standard PG 13.5 external thread so that they may be used with our HI 6054T holder, illustrated on page T2.25, as well as other common probe holders.



HI 7620 and HI 7621