

**From -40 to 550°C
in a Pocket Thermocouple
Thermometer**

KEY® is a K-type thermocouple thermometer with interchangeable probe for quick spot measurements of temperature. With a response time of less than 20 seconds in water, KEY® is ideal for quality control and routine industrial temperature monitoring.

There are 5 interchangeable temperature probes available to meet your specific requirements.

In the HVAC field, gas and air can be monitored with the HI 98517-11 probe. The HI 98517-13 probe is for penetration and is included with the meter. It also provides a fast response typical of a thermocouple probe.

HI 98517-15 and HI 98517-30 probes are for general liquid monitoring. The HI 98517-12 probe is made for machine shops, molding facilities and welding surfaces.

The casing of the meter is completely redesigned with a more ergonomic and appealing shape. Each probe is made of a rugged AISI 316 stainless steel, resisting the harmful effects of chemicals and humid conditions.

HI 98517 (KEY®C) provides temperature measurements in degrees Celsius, while the HI 98518 (KEY®F) model reads in degrees Fahrenheit.

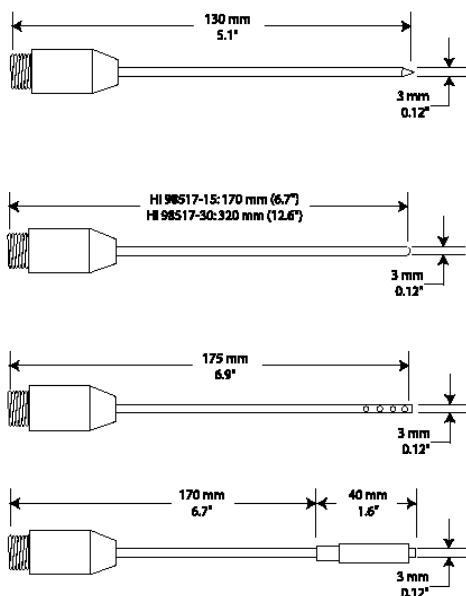

**HI 98517-13
penetration/general purpose**
K-type thermocouple probe supplied with KEY®. Application: liquid, air/gas, penetration of semisolids.

**HI 98517-15 and HI 98517-30
liquid/general purpose**
K-type thermocouple probe for KEY®. Application: liquids, air/gas.

HI 98517-11, air/gas
K-type thermocouple probe for KEY®. Application: air/gas.

HI 98517-12, surface
K-type thermocouple probe for KEY®. Application: solids, plates, furnaces, molds.

Specifications

	HI 98517 (KEY®C)	HI 98518 (KEY®F)
Range	-40 to 550°C	-40 to 999°F
Resolution	1°C	1°F
Accuracy	±2°C	±4°F
Response Time	approx. 20 seconds in water (with HI 98517-13 probe, included)	
Battery Type / Life	4 x 1.5V / approx. 700 hours of continuous use	
Environment	0 to 50°C (32 to 122°F); RH max 95%	
Dimensions (meter only)	175 x 41 x 23 mm (6.2 x 1.4 x 0.8")	
Weight	78 g (3.0 oz.)	

Accessories

HI 98517-11	K-thermocouple probe for air/gas	HI 98517-15	K-thermocouple probe for liquid/general purpose, length 170 mm (6.7")
HI 98517-12	K-thermocouple probe for surfaces	HI 98517-30	K-thermocouple probe for liquid/general purpose, length 320 mm (12.6")
HI 98517-13	K-thermocouple probe for penetration		

Ordering Information

HI 98517 (KEY®C) and HI 98518 (KEY®F) are supplied complete with HI 98517-13 probe, batteries and instructions.