

Instruction Manual

BL 983314-0
BL 983314-1

Panel-Mounted Resistivity Indicators & Controllers



WARRANTY

These instruments are warranted for two years against defects in workmanship and materials when used for their intended purpose and maintained according to instructions. Probes are warranted for six months. This warranty is limited to repair or replacement free of charge. Damages due to accident, misuse, tampering or lack of prescribed maintenance are not covered. If service is required, contact the dealer from whom you purchased the instrument. If under warranty, report the model number, date of purchase, serial number and the nature of the failure. If the repair is not covered by the warranty, you will be notified of the charges incurred. If the instrument is to be returned to Hanna Instruments, first obtain a Returned Goods Authorization Number from the Customer Service department and then send it with shipment costs prepaid. When shipping any instrument, make sure it is properly packaged for complete protection.

Recommendations for Users

Before using these products, make sure that they are entirely suitable for the environment in which they are used. Operation of these instruments in residential areas could cause unacceptable interferences to radio and TV equipment. The metal band at the end of the probe is sensitive to electrostatic discharges. Avoid touching this metal band at all times. During operation, ESD wrist straps should be worn to avoid possible damage to the probe by electrostatic discharges. Any variation introduced by the user to the supplied equipment may degrade the instrument's EMC performance. To avoid electrical shock, do not use these instruments when voltages at the measurement surface exceed 24 Vac or 60 Vdc. To avoid damages or burns, do not perform any measurement in microwave ovens.

Dear Customer,

Thank you for choosing a Hanna product.

This manual will provide you with the necessary information for the correct operation of the meter. Please read it carefully before using the instrument.

If you need additional technical information, do not hesitate to e-mail us at techserv@hannacan.com.

These instruments are in compliance with the **CE** directives.

PRELIMINARY EXAMINATION

Remove the instrument from the packing material and examine it carefully. If any damage has occurred during shipment, immediately notify your Dealer or the nearest Hanna Customer Service Center.

Each meter is supplied with:

- HI 3314 resistivity probe
- Mounting brackets
- Instruction manual

Note: Conserve all packing material until the instrument has been observed to function correctly. Any defective item must be returned in its original packing.

GENERAL DESCRIPTION

BL983314-0 and BL983314-1 resistivity indicators and controllers have been designed for continuous monitoring of process solutions.

The setpoint value can be fixed by acting on the trimmer on the front panel, and after selection of the required limit, the output relay allows to control an external dosing device.

Connections and wiring to probe, power supply and contacts are made via the terminal blocks on the rear panel.

The probe is easy to clean and requires little maintenance. Other features include: user-selectable temperature coefficient for readings compensation, overtime control system, multi-colour LED for indicating if the meter is in measurement/dosing/alarm condition, possibility to set (Off-Auto-On switch) dosing action mode.

Two models are available:

- **BL 983314-0** powered at 12 Vdc
- **BL 983314-1** powered at 115 or 230 Vac

SPECIFICATIONS

Range	0.00 to 19.90 M Ω /cm
Resolution	0.10 M Ω /cm
Accuracy (@ 20°C/68°F)	± 2% f.s.
Typical EMC Deviation	± 2% f.s.
Probe	HI 3314 resistivity probe (included)
Temp. Compensation	Automatic and Linear from 5 to 50°C (41 to 122°F)
Temperature Coefficient	$\beta = 2.4 ; 3.5 ; 4.5 \% / ^\circ C$ User-selectable through rear jumper
Calibration	Factory calibrated
Dosing Contact	Maximum 2A (fuse protected), 250 Vac, 30 Vdc Contact close when measure < setpoint
Setpoint	Adjustable, from 0 to 19.90 M Ω /cm
Overtime	Adjustable, typically from 5 to approx. 30 minutes
Power Consumption	10 VA
Installation Category	II
Power supply:	External (fuse protected)
BL983314-0	12 Vdc
BL983314-1	115/230 Vac ; 50/60Hz
Dimensions	83 x 53 x 99 mm (3.3x2.1x3.9")

ASSEMBLING VIEW

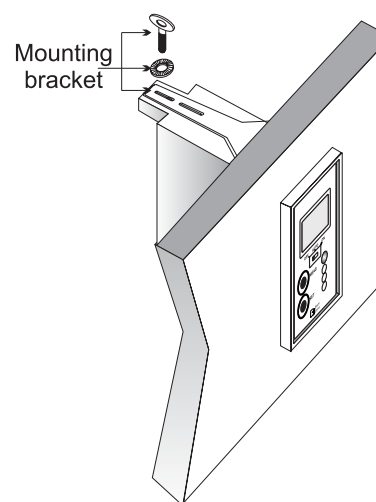

CE DECLARATION OF CONFORMITY



DECLARATION OF CONFORMITY

We

Hanna Instruments Italia Srl
viale delle Industrie, 12/A
35010 Ronchi di Villafranca - PD
ITALY

herewith certify that the Resistivity controllers:

BL983314-0 and BL983314-1

have been tested and found to be in compliance with EMC Directive 89/336/EEC and Low Voltage Directive 73/23/EEC according to the following applicable normatives:

EN 50082-1: Electromagnetic Compatibility - Generic Immunity Standard
IEC 61000-4-2: Electrostatic Discharge
IEC 61000-4-3: RF Radiated
IEC 61000-4-4: Fast Transient

EN 50081-1: Electromagnetic Compatibility - Generic Emission Standard
EN 55022: Radiated, Class B

EN61010-1: Safety requirements for electrical equipment for measurement, control and laboratory use

Date of Issue: 12.11.2003

A. Marsilio - Technical Director
On behalf of
Hanna Instruments S.r.l.

ACCESSORIES

HI 3314	Resistivity probe
HI 710005	12 Vdc power adapter, US plug
HI 710006	12 Vdc power adapter, European plug
HI 710012	12 Vdc power adapter, Australian plug
HI 710013	12 Vdc power adapter, South African plug
HI 710014	12 Vdc power adapter, UK plug
HI 731326	Calibration screwdriver (20 pcs)
HI 740146	Mounting brackets

FUNCTIONAL DESCRIPTION

Front panel

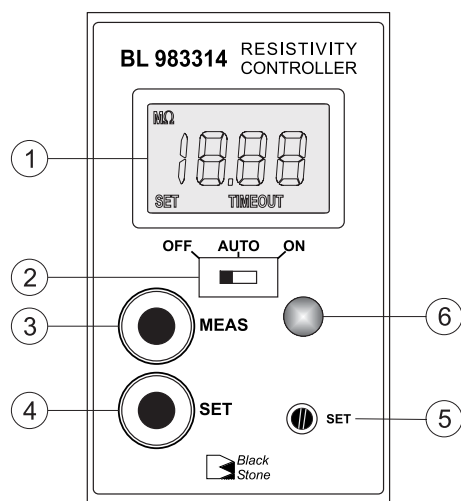

- Liquid Crystal Display
- Switch for selecting dosing mode:
 - OFF = dosing disabled
 - Auto = automatic dosage, depending on setpoint value
 - ON = dosing always active
- "MEAS" key to set the instrument to measurement mode
- "SET" key to display and set the setpoint value
- "SET" trimmer to adjust the setpoint value
- 3-colour LED indicator:
 - Green = meter in measurement mode
 - Orange/Yellow = dosing in progress
 - Red, blinking = indicates an alarm condition

Rear panel

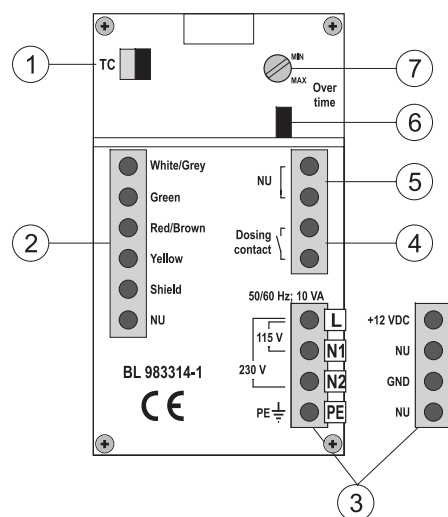

- TC jumper for selection of temperature coefficient (β)
- Connections for HI 3314 resistivity probe
- Power supply terminal:
 - for BL983314-0 model: 12 Vdc adapter
 - for BL983314-1 model: 115 Vac or 230 Vac option
- This contact acts as a switch for driving the dosing system (e.g. dosing pump)
- Not used contact
- Jumper for enabling (jumper in) or disabling (jumper removed) the overtime control
- Trimmer for overtime setting (typically from 5 to 30 minutes)



All external cables connected to the rear panel should end with cable lugs.



A circuit breaker (rated 6A max.) must be connected in close proximity to the equipment, and in a position easy to reach by the operator, for disconnection of the instrument and of all the devices connected to the relays.

OPERATIONS

REAR PANEL CONNECTIONS

Terminals #1: Probe

- Connect the supplied HI3314 probe by following the wires colour indications.

Terminals #2: Power Supply

- Model BL983314-0: connect the 2 wires of a 12 Vdc power adapter to the terminals +12 Vdc and GND.
- Model BL983314-1: connect a 3-wire power cable to the terminals while paying attention to the correct earth (PE), line (L) and neutral (N1 for 115 V or N2 for 230 V) contacts.

Terminals #3: Dosing Contact

- This contact drives the dosing system, accordingly to the selected setpoint.

Note: The setpoint has a typical hysteresis value comparable to the meter accuracy.

Terminals #4: Not Used Contact

Overtime system: jumper (#5) and trimmer (#6)

- This system allows the user to set a maximum dosing period, by adjusting the rear trimmer from 5 (min) to approx. 30 (max) minutes.
- When the set time is exceeded, any dosing action stops, the LED indicator on the front panel will blink Red and the LCD will show the "TIMEOUT" warning message. To exit the overtime condition, set the OFF/Auto/ON switch to "OFF" position, and then to "Auto" again.
- For disabling the overtime feature, simply remove the jumper on the rear panel.

Note: The overtime system works only if the OFF/Auto/ON switch is in "Auto" position.

OPERATING THE METER

Attach the resistivity probe to the meter and immerse it in the solution to be monitored while making sure that the metal pins are completely submerged.

Press the "MEAS" key (if necessary) and wait for a few seconds to allow stabilization of reading.

The LCD will display the resistivity value of the solution in $M\Omega/cm$ unit. The LED indicator will light up Green when the meter is in measurement mode and dosing is not active, while will light up Orange/Yellow for signaling that a dosing action is in progress.

CALIBRATION

The meter is factory calibrated.

If recalibration is needed, please contact your dealer or the nearest Hanna Service Center.

SETPOINT

Press the "SET" key: the display will show the default or previously adjusted value, together with the "SET" indication. Using a small screwdriver adjust the "SET" trimmer until the desired setpoint value is displayed.

After 1 minute the meter automatically returns to the normal mode; or press the "MEAS" key.

SELECTING TEMPERATURE COEFFICIENT

The reading is automatically corrected for temperature variations by using the linear compensation method:

$$R_{25} = R_t(1 + \beta(t-25))$$

where R_t is the resistivity at the temperature t .

The reference temperature is 25°C.

The coefficient β is user-selectable through the "TC" jumper on the rear panel.

Three values are available: 2.4, 3.5 or 4.5%/°C.

Follow the below diagram to set the desired coefficient.

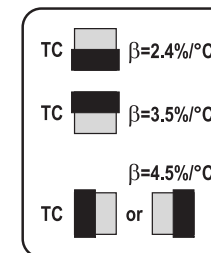

Note: If the coefficient 4.5%/°C is selected, a minimum measurement temperature of 10°C is suggested to maintain the best accuracy of the meter.