

Grower's Pal

pH & Fertilizer Control System for Reservoirs



Supplied Complete!
for only
2250.00 \$



www.hannacan.com

HANNA
instruments
CANADA
Agriculture Division
1-800-842-6629

Simplicity...

... and Security!

Easy to set up and install



Overdose timing protection for fertilizers & acid

Easy to use and program



Audible, visual & auxiliary alarms

Manual calibration & accurate digital readout



"No Flow" detection for recirculation circuit

Handy individual calibration solution packets



Waterproof, dustproof & rustproof. 2 year warranty.

Auto/Off/Prime switches for pump control. No more manual priming.



Factory trained service reps available on our toll free line (1-800-842-6629).

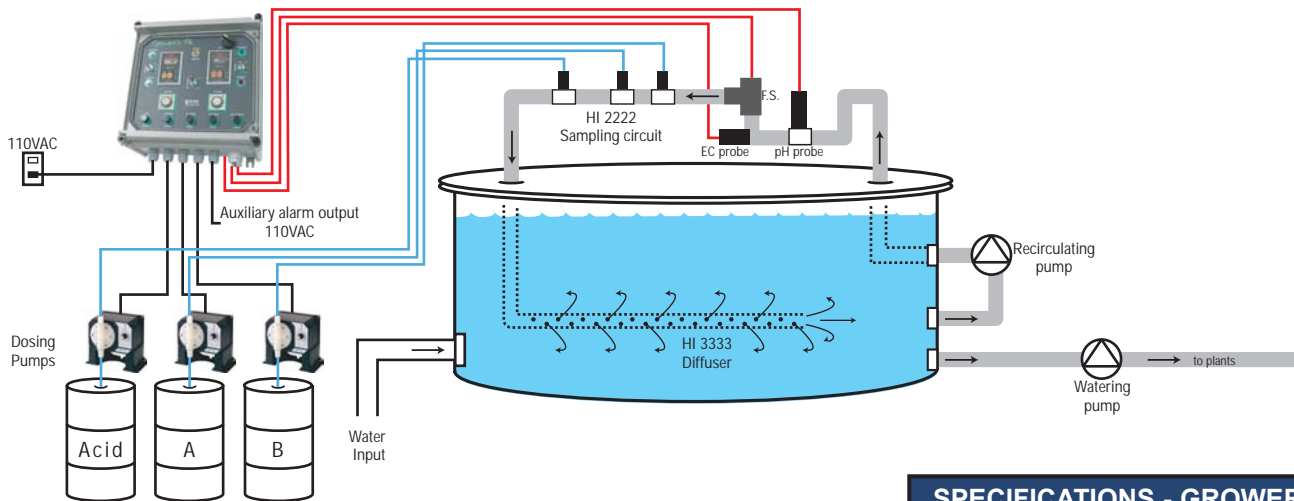

DOSING PUMPS

Hanna's dosing pumps are equipped with a single control for pump output. The external flow rate control (potentiometer) on the face of the pump allows you to adjust the percentage of flow from 0 to 100% of the pump's rated capacity.

- BL 20
- BL 15
- BL 10
- BL 7
- BL 5
- BL 3
- BL 1.5

- Kynar® materials dosing pump, 20 liter/hour
- Kynar® materials dosing pump, 15 liter/hour
- Kynar® materials dosing pump, 10 liter/hour
- Kynar® materials dosing pump, 7 liter/hour
- Kynar® materials dosing pump, 5 liter/hour
- Kynar® materials dosing pump, 3 liter/hour
- Kynar® materials dosing pump, 1.5 liter/hour

Supplied complete:

- polyethylene tubing (20')
- suction and discharge valves
- ceramic weights
- foot valve & filter
- injection fitting

SPECIFICATIONS - GROWER'S PAL

	pH	CONDUCTIVITY (EC)
RANGE	0.0 to 14.0 pH	0.00 to 19.99 mS/cm
RESOLUTION	0.1 pH	0.01 mS/cm
ACCURACY	±0.2 pH	±2% F.S.
INPUT	BNC	Bare wires
CALIBRATION	manual with mini-screwdriver	
TEMPERATURE COMPENSATION	N/A	automatic from 0 to 50°C
DISPLAY	LCD 4 segments	
DOSING OUTPUT	115VAC/4Amp. on power cord	
ALARM OUTPUT	115VAC/4Amp. on power cord	
AUDIBLE ALARM	piezoelectric	
VISUAL ALARM	1/2" red pilot light	
PUMPS CONTROL	auto/off/prime switch	
TIMERS	selectable from 0 to 30 minutes	
ENVIRONMENT	50°C / 95% humidity	
WEIGHT	11 lbs.	
POWER	115VAC 10 Amp.	